

REVISIONS			
LTR	DESCRIPTION	DATE (YR-MO-DA)	APPROVED
A	Make correction to both Input current ( $I_{ADJmin}$ ) tests unit column by deleting "mA" and replacing with "μA" as specified in Table I. Make correction to figure 2 block diagram. - ro	14-03-26	C. SAFFLE

ADI Rev B inputs 1/9/15  
& pg 17 correction 4/23/15

REV																					
SHEET																					
REV	A	A	A	A	A	A	A	A	A	A	A	A									
SHEET	15	16	17	18	19	20	21	22	23	24	25	26									
REV STATUS OF SHEETS	REV			A	A	A	A	A	A	A	A	A	A	A	A	A	A	A	A	A	
	SHEET			1	2	3	4	5	6	7	8	9	10	11	12	13	14				
PMIC N/A	PREPARED BY RICK OFFICER				<b>DLA LAND AND MARITIME COLUMBUS, OHIO 43218-3990</b> <a href="http://www.landandmaritime.dla.mil">http://www.landandmaritime.dla.mil</a>																
<b>STANDARD MICROCIRCUIT DRAWING</b>  THIS DRAWING IS AVAILABLE FOR USE BY ALL DEPARTMENTS AND AGENCIES OF THE DEPARTMENT OF DEFENSE  AMSC N/A	CHECKED BY RAJESH PITHADIA																				
	APPROVED BY CHARLES F. SAFFLE																				
	DRAWING APPROVAL DATE 12-06-22																				
	REVISION LEVEL A																				
				SIZE A	CAGE CODE <b>67268</b>	<b>5962-11203</b>															
				SHEET				1 OF 26													



1.3 Absolute maximum ratings. 1/

Supply voltage (V <sub>POS</sub> ) .....	5.5 V
Voltage at VSET pin .....	0 V to V <sub>POS</sub>
Input power (single ended, 50 Ω) .....	20 dBm
Internal power dissipation (P <sub>D</sub> ) .....	220 mW
Maximum junction temperature (T <sub>J</sub> ) .....	+150°C
Lead temperature (soldering, 60 seconds) .....	260°C
Storage temperature range .....	-65°C to +150°C
Thermal resistance, junction-to-case (θ <sub>JC</sub> ) .....	53°C/W 2/
Thermal resistance, junction-to-ambient (θ <sub>JA</sub> ) .....	66°C/W 3/

1.4 Recommended operating conditions.

Supply voltage (V <sub>POS</sub> ) .....	2.7 V to 5 V
Ambient operating temperature range (T <sub>A</sub> ) .....	-55°C to +125°C

1.4.1 Operating performance characteristics. 4/

Dynamic range:

100 MHz, ±3.0 dB .....	67 dB
900 MHz, ±3.0 dB .....	74 dB
2140 MHz, ±3.0 dB .....	76 dB
4000 MHz, ±3.0 dB .....	70 dB
100 MHz, ±1.0 dB .....	58 dB
900 MHz, ±1.0 dB .....	69 dB
2140 MHz, ±1.0 dB .....	68 dB
4000 MHz, ±1.0 dB .....	61 dB
100 MHz, ±0.5 dB .....	50 dB
900 MHz, ±0.5 dB .....	67 dB
2140 MHz, ±0.5 dB .....	66 dB
4000 MHz, ±0.5 dB .....	56 dB

Input level, ±1.0 dB:

100 MHz, radio frequency (RF) maximum .....	6 dBm
100 MHz, RF minimum .....	-52 dBm
900 MHz, RF maximum .....	7 dBm
900 MHz, RF minimum .....	-62 dBm
2140 MHz, RF maximum .....	2 dBm
2140 MHz, RF minimum .....	-70 dBm
4000 MHz, RF maximum .....	6 dBm
4000 MHz, RF minimum .....	-55 dBm

- 1/ Stresses above the absolute maximum rating may cause permanent damage to the device. Extended operation at the maximum levels may degrade performance and affect reliability.
- 2/ Measurement taken under absolute worst case conditions. Data taken with a thermal camera for highest power density location. See MIL-STD-1835 for average package thermal numbers.
- 3/ Measurement taken under absolute worst case conditions. Data taken with a thermal camera for highest power density location.
- 4/ Unless otherwise specified, V<sub>POS</sub> = 2.7 V to 5 V, V<sub>TADJ</sub> is per paragraph 6.7.5. T<sub>A</sub> = +25°C.

<b>STANDARD MICROCIRCUIT DRAWING</b> DLA LAND AND MARITIME COLUMBUS, OHIO 43218-3990	SIZE <b>A</b>		<b>5962-11203</b>
		REVISION LEVEL A	SHEET 3

1.4.1 Operating performance characteristics – continued. 4/

RF input impedance:

100 MHz .....	1.3 k $\Omega$
900 MHz .....	1.3 k $\Omega$
2140 MHz .....	0.5 k $\Omega$
4000 MHz .....	0.5 k $\Omega$

RF input capacitance:

100 MHz .....	0.4 pF
900 MHz .....	0.4 pF
2140 MHz .....	0.5 pF
4000 MHz .....	0.4 pF

V<sub>OUT</sub> output capacitance:

CLPF = open .....	47 pF
CLPF = 20 pF .....	1 nF

V<sub>OUT</sub> output noise, RF input = 100 MHz, 0 dBm:

f <sub>noise</sub> = 100 kHz, CLPF = open .....	145 nV / $\sqrt{\text{Hz}}$
f <sub>noise</sub> = 100 kHz, CLPF = 1 nF .....	82 nV / $\sqrt{\text{Hz}}$

TADJ response time,

TADJ low (enable) to V<sub>OUT</sub> 100%, TADJ high (disable) to V<sub>OUT</sub> 10%,  
RF input = 0 dBm, 100 MHz, 1  $\mu$ s pulse width

Enable time, CLPF = open .....	84 ns
Enable time, CLPF = 1000 pF .....	10.8 $\mu$ s
Disable time, CLPF = open .....	165 ns
Disable time, CLPF = 1000 pF .....	1.2 $\mu$ s

TADJ input Impedance, TADJ = 0.9 V, sourcing 70  $\mu$ A ..... 13 k $\Omega$

1.5 Radiation features.

Maximum total dose available (dose rate = 50 – 300 rads(Si)/s) ..... 100 krads(Si) 5/

5/ These parts may be dose rate sensitive in a space environment and may demonstrate enhanced low dose rate effects. Radiation end point limits for the noted parameters are guaranteed only for the conditions specified in MIL-STD-883, method 1019, condition A.

<b>STANDARD MICROCIRCUIT DRAWING</b> DLA LAND AND MARITIME COLUMBUS, OHIO 43218-3990	SIZE <b>A</b>		<b>5962-11203</b>
		REVISION LEVEL <b>A</b>	SHEET <b>4</b>

## 2. APPLICABLE DOCUMENTS

2.1 Government specification, standards, and handbooks. The following specification, standards, and handbooks form a part of this drawing to the extent specified herein. Unless otherwise specified, the issues of these documents are those cited in the solicitation or contract.

### DEPARTMENT OF DEFENSE SPECIFICATION

MIL-PRF-38535 - Integrated Circuits, Manufacturing, General Specification for.

### DEPARTMENT OF DEFENSE STANDARDS

MIL-STD-883 - Test Method Standard Microcircuits.  
MIL-STD-1835 - Interface Standard Electronic Component Case Outlines.

### DEPARTMENT OF DEFENSE HANDBOOKS

MIL-HDBK-103 - List of Standard Microcircuit Drawings.  
MIL-HDBK-780 - Standard Microcircuit Drawings.

(Copies of these documents are available online at <http://quicksearch.dla.mil> or from the Standardization Document Order Desk, 700 Robbins Avenue, Building 4D, Philadelphia, PA 19111-5094.)

2.2 Order of precedence. In the event of a conflict between the text of this drawing and the references cited herein, the text of this drawing takes precedence. Nothing in this document, however, supersedes applicable laws and regulations unless a specific exemption has been obtained.

## 3. REQUIREMENTS

3.1 Item requirements. The individual item requirements for device classes Q and V shall be in accordance with MIL-PRF-38535 as specified herein, or as modified in the device manufacturer's Quality Management (QM) plan. The modification in the QM plan shall not affect the form, fit, or function as described herein.

3.2 Design, construction, and physical dimensions. The design, construction, and physical dimensions shall be as specified in MIL-PRF-38535 and herein for device classes Q and V.

3.2.1 Case outline. The case outline shall be in accordance with 1.2.4 herein.

3.2.2 Terminal connections. The terminal connections shall be as specified on figure 1.

3.2.3 Block diagram. The block diagram shall be as specified on figure 2.

3.2.4 Radiation exposure circuit. The radiation exposure circuit shall be maintained by the manufacturer under document revision level control and shall be made available to the preparing and acquiring activity upon request.

3.3 Electrical performance characteristics and postirradiation parameter limits. Unless otherwise specified herein, the electrical performance characteristics and postirradiation parameter limits are as specified in table I and shall apply over the full ambient operating temperature range.

3.4 Electrical test requirements. The electrical test requirements shall be the subgroups specified in table IIA. The electrical tests for each subgroup are defined in table I.

3.5 Marking. The part shall be marked with the PIN listed in 1.2 herein. In addition, the manufacturer's PIN may also be marked. For packages where marking of the entire SMD PIN number is not feasible due to space limitations, the manufacturer has the option of not marking the "5962-" on the device. For RHA product using this option, the RHA designator shall still be marked. Marking for device classes Q and V shall be in accordance with MIL-PRF-38535.

3.5.1 Certification/compliance mark. The certification mark for device classes Q and V shall be a "QML" or "Q" as required in MIL-PRF-38535.

<b>STANDARD MICROCIRCUIT DRAWING</b> DLA LAND AND MARITIME COLUMBUS, OHIO 43218-3990	SIZE <b>A</b>		<b>5962-11203</b>
		REVISION LEVEL A	SHEET 5

TABLE I. Electrical performance characteristics.

Test	Symbol	Conditions <u>1/ 2/ 3/ 4/</u> -55°C ≤ T <sub>A</sub> ≤ +125°C V <sub>POS</sub> = 5.0 V unless otherwise specified	Group A subgroups	Device type	Limits		Unit				
					Min	Max					
RF <sub>IN</sub> frequency = 100 MHz											
Logarithmic slope <u>5/</u>	Slope		4	01	19.4	22.6	mV/dB				
			5		20.2	21.6					
			6		20.4	22.3					
			M,D,P,L,R		4	19.4		22.6			
Logarithmic intercept <u>5/</u>	Intercept		4	01	-96.7	-79.3	dBm				
			5		-96.9	-80.8					
			6		-96.5	-77.9					
			M,D,P,L,R		4	-96.7		-79.3			
V <sub>OUT</sub> voltage	V <sub>O</sub>	RF <sub>IN</sub> = -10 dBm	4,5,6	01	1.45	1.81	V				
			M,D,P,L,R		4	1.45		1.81			
		RF <sub>IN</sub> = -30 dBm	4,5,6		1.03	1.39					
			M,D,P,L,R		4	1.03		1.39			
		RF <sub>IN</sub> = -50 dBm	4,5,6		0.59	0.99					
			M,D,P,L,R		4	0.59		0.99			
		Deviation from log linear <u>5/</u>	Linear error		RF <sub>IN</sub> = -10 dBm	4,5,6		01	-1.1	1.1	dB
						M,D,P,L,R			4	-1.1	
RF <sub>IN</sub> = -30 dBm	4,5,6			-0.6	0.6						
	M,D,P,L,R			4	-0.6	0.6					
RF <sub>IN</sub> = -50 dBm	4			-2.1	2.1						
	5,6			-2.5	2.5						
M,D,P,L,R	4			-2.1	2.1						

See footnotes at end of table.

<b>STANDARD MICROCIRCUIT DRAWING</b> DLA LAND AND MARITIME COLUMBUS, OHIO 43218-3990	SIZE <b>A</b>		<b>5962-11203</b>
		REVISION LEVEL A	SHEET 6

TABLE I. Electrical performance characteristics – Continued.

Test	Symbol	Conditions <u>1/ 2/ 3/ 4/</u> -55°C ≤ T <sub>A</sub> ≤ +125°C V <sub>POS</sub> = 5.0 V unless otherwise specified	Group A subgroups	Device type	Limits		Unit				
					Min	Max					
RF <sub>IN</sub> frequency = 900 MHz											
Logarithmic slope <u>5/</u>	Slope		4	01	20.9	22.3	mV/dB				
			5		20.6	21.9					
			6		20.8	22.4					
			M,D,P,L,R		20.9	22.3					
Logarithmic intercept <u>5/</u>	Intercept		4	01	-102.2	-84.2	dBm				
			5		-102.4	-85.3					
			6		-102.5	-83.3					
			M,D,P,L,R		-102.2	-84.2					
V <sub>OUT</sub> voltage	V <sub>O</sub>	RF <sub>IN</sub> = -10 dBm	4,5,6	01	1.60	1.96	V				
			M,D,P,L,R		4	1.60		1.96			
		RF <sub>IN</sub> = -30 dBm	4,5,6		1.18	1.54					
			M,D,P,L,R		4	1.18		1.54			
		RF <sub>IN</sub> = -50 dBm	4,5,6		0.72	1.08					
			M,D,P,L,R		4	0.72		1.08			
		Deviation from log linear <u>5/</u>	Linear error		RF <sub>IN</sub> = -10 dBm	4,5,6		01	-1.1	1.1	dB
						M,D,P,L,R			4	-1.1	
RF <sub>IN</sub> = -30 dBm	4,5,6			-0.6	0.6						
	M,D,P,L,R			4	-0.6	0.6					
RF <sub>IN</sub> = -50 dBm	4			-2.1	2.1						
	5,6			-2.5	2.5						
M,D,P,L,R	4			-2.1	2.1						

See footnotes at end of table.

<b>STANDARD MICROCIRCUIT DRAWING</b> DLA LAND AND MARITIME COLUMBUS, OHIO 43218-3990	SIZE <b>A</b>		<b>5962-11203</b>
		REVISION LEVEL A	SHEET 7

TABLE I. Electrical performance characteristics – Continued.

Test	Symbol	Conditions <u>1/ 2/ 3/ 4/</u> -55°C ≤ T <sub>A</sub> ≤ +125°C V <sub>POS</sub> = 5.0 V unless otherwise specified	Group A subgroups	Device type	Limits		Unit				
					Min	Max					
RF <sub>IN</sub> frequency = 2140 MHz											
Logarithmic slope <u>5/</u>	Slope		4	01	19.7	24.2	mV/dB				
			5		19.2	23.8					
			6		21.3	23.7					
			M,D,P,L,R		4	19.7		24.2			
Logarithmic intercept <u>5/</u>	Intercept		4	01	-89.8	-71	dBm				
			5		-92.8	-68.4					
			6		-93.6	-67					
			M,D,P,L,R		4	-89.8		-71			
V <sub>OUT</sub> voltage	V <sub>O</sub>	RF <sub>IN</sub> = -10 dBm	4,5,6	01	1.34	1.84	V				
			M,D,P,L,R		4	1.34		1.84			
		RF <sub>IN</sub> = -30 dBm	4,5,6		0.91	1.41					
			M,D,P,L,R		4	0.91		1.41			
		RF <sub>IN</sub> = -45 dBm	4,5,6		0.53	1.03					
			M,D,P,L,R		4	0.53		1.03			
		Deviation from log linear <u>5/</u>	Linear error		RF <sub>IN</sub> = -10 dBm	4		01	-1.6	1.6	dB
						5,6			-1.65	1.65	
M,D,P,L,R	4			-1.6	1.6						
	RF <sub>IN</sub> = -30 dBm			4,5,6	-0.6	0.6					
M,D,P,L,R				4	-0.6	0.6					
	RF <sub>IN</sub> = -45 dBm			4	-1.6	1.6					
5				-2.0	2.0						
6				-1.2	1.2						
M,D,P,L,R				4	-1.6	1.6					

See footnotes at end of table.

<b>STANDARD MICROCIRCUIT DRAWING</b> DLA LAND AND MARITIME COLUMBUS, OHIO 43218-3990	SIZE <b>A</b>		<b>5962-11203</b>
		REVISION LEVEL A	SHEET 8

TABLE I. Electrical performance characteristics – Continued.

Test	Symbol	Conditions <u>1/ 2/ 3/ 4/</u> -55°C ≤ T <sub>A</sub> ≤ +125°C V <sub>POS</sub> = 5.0 V unless otherwise specified	Group A subgroups	Device type	Limits		Unit				
					Min	Max					
RF <sub>IN</sub> frequency = 4000 MHz											
Logarithmic slope <u>5/</u>	Slope		4	01	22.4	25.1	mV/dB				
			5		22.7	25.9					
			6		21.2	25					
			M,D,P,L,R		4	22.4		25.1			
Logarithmic intercept <u>5/</u>	Intercept		4	01	-92.9	-74.7	dBm				
			5		-92.2	-74.8					
			6		-96	-75.4					
			M,D,P,L,R		4	-92.9		-74.7			
V <sub>OUT</sub> voltage	V <sub>O</sub>	RF <sub>IN</sub> = -10 dBm	4,5,6	01	1.51	1.88	V				
			M,D,P,L,R		4	1.51		1.88			
		RF <sub>IN</sub> = -30 dBm	4,5,6		1.05	1.41					
			M,D,P,L,R		4	1.05		1.41			
		RF <sub>IN</sub> = -50 dBm	4,5,6		0.51	0.87					
			M,D,P,L,R		4	0.51		0.87			
		Deviation from log linear <u>5/</u>	Linear error		RF <sub>IN</sub> = -10 dBm	4		01	-1.3	1.3	dB
						5			-1.35	1.35	
6	-1.35			1.35							
M,D,P,L,R	4			-1.3	1.3						
RF <sub>IN</sub> = -30 dBm	4,5,6			-0.6	0.6						
	M,D,P,L,R			4	-0.6	0.6					
RF <sub>IN</sub> = -50 dBm	4			-2.5	2.5						
	5,6			-2.9	2.9						
	M,D,P,L,R			4	-2.5	2.5					

See footnotes at end of table.

<b>STANDARD MICROCIRCUIT DRAWING</b> DLA LAND AND MARITIME COLUMBUS, OHIO 43218-3990	SIZE <b>A</b>		<b>5962-11203</b>
		REVISION LEVEL A	SHEET 9

TABLE I. Electrical performance characteristics – Continued.

Test	Symbol	Conditions <u>1/ 2/ 3/ 4/</u> -55°C ≤ T <sub>A</sub> ≤ +125°C V <sub>POS</sub> = 5.0 V unless otherwise specified	Group A subgroups	Device type	Limits		Unit
					Min	Max	
Setpoint input (V <sub>SET</sub> ) section.							
Logarithmic scale factor	LSF	RF <sub>IN</sub> frequency = 100 MHz	4,6	01	39	53	dB/V
			5		37	53	
			M,D,P,L,R		4	39	
		RF <sub>IN</sub> frequency = 900 MHz	4,6		39	53	
			5		37	53	
			M,D,P,L,R		4	39	
		RF <sub>IN</sub> frequency = 2140 MHz	4,6		39	53	
			5		37	53	
			M,D,P,L,R		4	39	
		RF <sub>IN</sub> frequency = 4000 MHz	4,6		39	53	
			5		37	53	
			M,D,P,L,R		4	39	
Output interface (V <sub>OUT</sub> ) section.							
Voltage swing	V <sub>Omax</sub>	V <sub>SET</sub> = 1.0 V, RF <sub>IN</sub> = -5 dBm, V <sub>OUT</sub> not connected to V <sub>SET</sub>	1	01	4.79	V <sub>POS</sub>	V
			2,3		4.79	V <sub>POS</sub>	
			M,D,P,L,R		1	4.79	
	V <sub>Omin</sub>	V <sub>SET</sub> = 1.0 V, RF <sub>IN</sub> = open, V <sub>OUT</sub> not connected to V <sub>SET</sub>	1		0	0.06	
			2,3		0	0.06	
			M,D,P,L,R		1	0	
Current source/sink <u>6/ 7/</u>	I <sub>Osource</sub>		1	01		-44	mA
			2			-55	
			3			-40	
	I <sub>Osink</sub>		1		0.55		
			2		0.55		
			3		0.55		

See footnotes at end of table.

<b>STANDARD MICROCIRCUIT DRAWING</b> DLA LAND AND MARITIME COLUMBUS, OHIO 43218-3990	SIZE <b>A</b>		<b>5962-11203</b>
		REVISION LEVEL A	SHEET 10

TABLE I. Electrical performance characteristics – Continued.

Test	Symbol	Conditions <u>1/ 2/ 3/ 4/</u> -55°C ≤ T <sub>A</sub> ≤ +125°C V <sub>POS</sub> = 5.0 V unless otherwise specified	Group A subgroups	Device type	Limits		Unit
					Min	Max	
Output interface (V <sub>OUT</sub> ) section – continued.							
VO offset in measurement mode	offset <sub>MM</sub>	RF <sub>IN</sub> open (no RF), V <sub>OUT</sub> connected to V <sub>SET</sub> , V <sub>dis</sub> /TADJ = 1.3 V	1	01	0.25	1.12	V
			2		0.25	1.12	
			3		0.15	1.08	
		M,D,P,L,R	1	0.25	1.12		
Temperature adjust/power down function (TADJ) section.							
Input voltage <u>8/</u>	V <sub>dis</sub>	High voltage to disable M,D,P,L,R	1,2,3	01	4.7		V
			1		4.7		
	V <sub>adj</sub>	Voltage without disable M,D,P,L,R	1,2,3			1.3	
			1			1.3	
Input current	I <sub>ADJmin</sub>	TADJ = 0 V M,D,P,L,R	1	01	-160		μA
			2,3		-160		
			1		-160		
	I <sub>ADJmax</sub>	TADJ = 4.7 V M,D,P,L,R	1			450	
			2,3			450	
			1			450	
Power supply interface (V <sub>POS</sub> ) section.							
Quiescent supply current	I <sub>Q</sub>	RF in = -55 dBm, V <sub>POS</sub> = 5 V and 5.25 V	1	01	26	33	mA
			2		35	42	
			3		17	25	
		M,D,P,L,R	1		26	33	
Disabled supply current	I <sub>dis</sub>	V <sub>dis</sub> /TADJ = 4.7 V, V <sub>POS</sub> = 5 V and 5.25 V	1	01	50	300	μA
			2		150	475	
			3		50	300	
		M,D,P,L,R	1		50	300	

See footnotes at end of table.

<b>STANDARD MICROCIRCUIT DRAWING</b> DLA LAND AND MARITIME COLUMBUS, OHIO 43218-3990	SIZE <b>A</b>		<b>5962-11203</b>
		REVISION LEVEL A	SHEET 11

TABLE I. Electrical performance characteristics – Continued.

Test	Symbol	Conditions <u>1/ 2/ 3/ 4/</u> -55°C ≤ T <sub>A</sub> ≤ +125°C V <sub>POS</sub> = 5.0 V unless otherwise specified	Group A subgroups	Device type	Limits		Unit
					Min	Max	
RF input pulse response time section.							
V <sub>O</sub> rise time: <u>7/</u> 10% to 90% RF in = no signal to 0 dB at 100 MHz	t <sub>RISE</sub>	CLPF = open, 50 μs pulse	9	01		27.5	ns
			10			28.0	
			11			27.5	
		CLPF = 1000 pF, 50 μs pulse	9			4.7	μs
			10			4.5	
			11			4.3	
V <sub>O</sub> fall time: <u>7/</u> 90% to 10% RF in = no signal to 0 dB at 100 MHz	t <sub>FALL</sub>	CLPF = open, 50 μs pulse	9	01		29.1	ns
			10			29.3	
			11			26.2	
		CLPF = 1000 pF, 50 μs pulse	9			7.8	μs
			10			9.0	
			11			7.7	

See footnotes at end of table.

<b>STANDARD MICROCIRCUIT DRAWING</b> DLA LAND AND MARITIME COLUMBUS, OHIO 43218-3990	SIZE <b>A</b>		<b>5962-11203</b>
		REVISION LEVEL <b>A</b>	SHEET 12

TABLE I. Electrical performance characteristics – Continued.

Test	Symbol	Conditions <u>1/ 2/ 3/ 4/</u> -55°C ≤ T <sub>A</sub> ≤ +125°C V <sub>POS</sub> = 2.7 V unless otherwise specified	Group A subgroups	Device type	Limits		Unit				
					Min	Max					
RF <sub>IN</sub> frequency = 100 MHz											
Logarithmic slope <u>5/</u>	Slope		4	01	20.5	21.9	mV/dB				
			5		20.2	21.6					
			6		20.6	22.2					
			M,D,P,L,R		4	20.5		21.9			
Logarithmic intercept <u>5/</u>	Intercept		4	01	-95.6	-78.8	dBm				
			5		-96.2	-79.8					
			6		95.6	77.1					
			M,D,P,L,R		4	-95.6		-78.8			
V <sub>OUT</sub> voltage	V <sub>O</sub>	RF <sub>IN</sub> = -10 dBm	4,5,6	01	1.43	1.79	V				
			M,D,P,L,R		4	1.43		1.79			
		RF <sub>IN</sub> = -30 dBm	4,5,6		0.93	1.43					
			M,D,P,L,R		4	0.93		1.43			
		RF <sub>IN</sub> = -50 dBm	4,5,6		0.59	0.95					
			M,D,P,L,R		4	0.59		0.95			
		Deviation from log linear <u>5/</u>	Linear error		RF <sub>IN</sub> = -10 dBm	4,5,6		01	-1.1	1.1	dB
						M,D,P,L,R			4	-1.1	
RF <sub>IN</sub> = -30 dBm	4,5,6			-0.6	0.6						
	M,D,P,L,R			4	-0.6	0.6					
RF <sub>IN</sub> = -50 dBm	4			-2.1	2.1						
	5,6			-2.5	2.5						
M,D,P,L,R	4			-2.1	2.1						

See footnotes at end of table.

<b>STANDARD MICROCIRCUIT DRAWING</b> DLA LAND AND MARITIME COLUMBUS, OHIO 43218-3990	SIZE <b>A</b>		<b>5962-11203</b>
		REVISION LEVEL A	SHEET 13

TABLE I. Electrical performance characteristics – Continued.

Test	Symbol	Conditions <u>1/ 2/ 3/ 4/</u> -55°C ≤ T <sub>A</sub> ≤ +125°C V <sub>POS</sub> = 2.7 V unless otherwise specified	Group A subgroups	Device type	Limits		Unit				
					Min	Max					
RF <sub>IN</sub> frequency = 900 MHz											
Logarithmic slope <u>5/</u>	Slope		4	01	20.8	22.1	mV/dB				
			5		20.6	22					
			6		20.8	22.3					
			M,D,P,L,R		20.8	22.1					
Logarithmic intercept <u>5/</u>	Intercept		4	01	-101.7	-83.8	dBm				
			5		-101.7	-84.9					
			6		-102.7	-82.8					
			M,D,P,L,R		-101.7	-83.8					
V <sub>OUT</sub> voltage	V <sub>O</sub>	RF <sub>IN</sub> = -10 dBm	4,5,6	01	1.58	1.94	V				
			M,D,P,L,R		4	1.58		1.94			
		RF <sub>IN</sub> = -30 dBm	4,5,6		1.16	1.52					
			M,D,P,L,R		4	1.16		1.52			
		RF <sub>IN</sub> = -50 dBm	4,5,6		0.71	1.07					
			M,D,P,L,R		4	0.71		1.07			
		Deviation from log linear <u>5/</u>	Linear error		RF <sub>IN</sub> = -10 dBm	4,5,6		01	-1.1	1.1	dB
						M,D,P,L,R			4	-1.1	
RF <sub>IN</sub> = -30 dBm	4,5,6			-0.6	0.6						
	M,D,P,L,R			4	-0.6	0.6					
RF <sub>IN</sub> = -50 dBm	4			-2.1	2.1						
	5,6			-2.5	2.5						
M,D,P,L,R	4			-2.1	2.1						

See footnotes at end of table.

<b>STANDARD MICROCIRCUIT DRAWING</b> DLA LAND AND MARITIME COLUMBUS, OHIO 43218-3990	SIZE <b>A</b>		<b>5962-11203</b>
		REVISION LEVEL A	SHEET 14

TABLE I. Electrical performance characteristics – Continued.

Test	Symbol	Conditions <u>1/ 2/ 3/ 4/</u> -55°C ≤ T <sub>A</sub> ≤ +125°C V <sub>POS</sub> = 2.7 V unless otherwise specified	Group A subgroups	Device type	Limits		Unit				
					Min	Max					
RF <sub>IN</sub> frequency = 2140 MHz											
Logarithmic slope <u>5/</u>	Slope		4	01	19.7	24.5	mV/dB				
			5		19.6	23.8					
			6		21.4	23.9					
			M,D,P,L,R		4	19.7		24.5			
Logarithmic intercept <u>5/</u>	Intercept		4	01	-89	-69.4	dBm				
			5		-91.4	-67.4					
			6		-92.6	-65.8					
			M,D,P,L,R		4	-89		-69.4			
V <sub>OUT</sub> voltage	V <sub>O</sub>	RF <sub>IN</sub> = -10 dBm	4,5,6	01	1.33	1.83	V				
			M,D,P,L,R		4	1.33		1.83			
		RF <sub>IN</sub> = -30 dBm	4,5,6		0.89	1.39					
			M,D,P,L,R		4	0.89		1.39			
		RF <sub>IN</sub> = -45 dBm	4,5,6		0.49	0.98					
			M,D,P,L,R		4	0.49		0.98			
		Deviation from log linear <u>5/</u>	Linear error		RF <sub>IN</sub> = -10 dBm	4		01	-1.6	1.6	dB
						5,6			-1.65	1.65	
M,D,P,L,R	4			-1.6	1.6						
	RF <sub>IN</sub> = -30 dBm			4,5,6	-0.6	0.6					
M,D,P,L,R				4	-0.6	0.6					
	RF <sub>IN</sub> = -45 dBm			4	-1.6	1.6					
5				-2.0	2.0						
6				-1.4	1.4						
M,D,P,L,R				4	-1.6	1.6					

See footnotes at end of table.

<b>STANDARD MICROCIRCUIT DRAWING</b> DLA LAND AND MARITIME COLUMBUS, OHIO 43218-3990	SIZE <b>A</b>		<b>5962-11203</b>
		REVISION LEVEL A	SHEET 15

TABLE I. Electrical performance characteristics – Continued.

Test	Symbol	Conditions <u>1/ 2/ 3/ 4/</u> -55°C ≤ T <sub>A</sub> ≤ +125°C V <sub>POS</sub> = 2.7 V unless otherwise specified	Group A subgroups	Device type	Limits		Unit				
					Min	Max					
RF <sub>IN</sub> frequency = 4000 MHz											
Logarithmic slope <u>5/</u>	Slope		4	01	22.3	25.1	mV/dB				
			5		22.6	25.7					
			6		21.3	24.9					
			M,D,P,L,R		4	22.3		25.1			
Logarithmic intercept <u>5/</u>	Intercept		4	01	-93.1	-73.5	dBm				
			5		91.5	-74.5					
			6		-94.9	-74.9					
			M,D,P,L,R		4	-93.1		-73.5			
V <sub>OUT</sub> voltage	V <sub>O</sub>	RF <sub>IN</sub> = -10 dBm	4,5,6	01	1.49	1.86	V				
			M,D,P,L,R		4	1.49		1.86			
		RF <sub>IN</sub> = -30 dBm	4,5,6		1.03	1.39					
			M,D,P,L,R		4	1.03		1.39			
		RF <sub>IN</sub> = -50 dBm	4,5,6		0.5	0.86					
			M,D,P,L,R		4	0.5		0.86			
		Deviation from log linear <u>5/</u>	Linear error		RF <sub>IN</sub> = -10 dBm	4,5,6		01	-1.3	1.3	dB
						M,D,P,L,R			4	-1.3	
RF <sub>IN</sub> = -30 dBm	4,5,6			-0.6	0.6						
	M,D,P,L,R			4	-0.6	0.6					
RF <sub>IN</sub> = -50 dBm	4			-2.5	2.5						
	5,6			-2.9	2.9						
M,D,P,L,R	4			-2.5	2.5						

See footnotes at end of table.

<b>STANDARD MICROCIRCUIT DRAWING</b> DLA LAND AND MARITIME COLUMBUS, OHIO 43218-3990	SIZE <b>A</b>		<b>5962-11203</b>
		REVISION LEVEL A	SHEET 16

TABLE I. Electrical performance characteristics – Continued.

Test	Symbol	Conditions <u>1/ 2/ 3/ 4/</u> -55°C ≤ T <sub>A</sub> ≤ +125°C V <sub>POS</sub> = 2.7 V unless otherwise specified	Group A subgroups	Device type	Limits		Unit
					Min	Max	
Setpoint input (V <sub>SET</sub> ) section							
Logarithmic scale factor	LSF	RF <sub>IN</sub> frequency = 100 MHz	4,6	01	39	53	dB/V
			5		37	53	
		M,D,P,L,R	4		39	53	
			RF <sub>IN</sub> frequency = 900 MHz		4,6	39	
		5			37	53	
		M,D,P,L,R	4		39	53	
			RF <sub>IN</sub> frequency = 2140 MHz		4,6	39	
		5			37	53	
		M,D,P,L,R	4		39	53	
			RF <sub>IN</sub> frequency = 4000 MHz		4,6	39	
		5			37	53	
		M,D,P,L,R	4		39	53	
Output interface (V <sub>OUT</sub> ) section.							
Voltage swing	V <sub>Omax</sub>	V <sub>SET</sub> = 1.0 V, RF <sub>IN</sub> = -5 dBm, V <sub>OUT</sub> not connected to V <sub>SET</sub>	1	01	2.57	V <sub>POS</sub>	V
			2,3		2.57	V <sub>POS</sub>	
		M,D,P,L,R	1		2.57	V <sub>POS</sub>	
	V <sub>Omin</sub>	V <sub>SET</sub> = 1.0 V, RF <sub>IN</sub> = open, V <sub>OUT</sub> not connected to V <sub>SET</sub>	1		0	0.06	
			2,3		0	0.06	
		M,D,P,L,R	1		0	0.06	
Current source/sink <u>6/ 7/</u>	I <sub>Osource</sub>		1	01		-36	mA
			2,3			-38	
			<del>M,D,P,L,R</del>		<del>4</del>	<del>-33</del>	
	I <sub>Osink</sub>		1		0.55		
			2,3		0.52		
			<del>M,D,P,L,R</del>		<del>4</del>	<del>0.57</del>	

See footnotes at end of table.

<b>STANDARD MICROCIRCUIT DRAWING</b> DLA LAND AND MARITIME COLUMBUS, OHIO 43218-3990	SIZE <b>A</b>		<b>5962-11203</b>
		REVISION LEVEL <b>A</b>	SHEET <b>17</b>

TABLE I. Electrical performance characteristics – Continued.

Test	Symbol	Conditions <u>1/ 2/ 3/ 4/</u> -55°C ≤ T <sub>A</sub> ≤ +125°C V <sub>POS</sub> = 2.7 V unless otherwise specified	Group A subgroups	Device type	Limits		Unit
					Min	Max	
Output interface (V <sub>OUT</sub> ) section – continued.							
VO offset in measurement mode	offset <sub>MM</sub>	RF <sub>IN</sub> open (no RF), V <sub>OUT</sub> connected to V <sub>SET</sub> , V <sub>dis</sub> /T <sub>ADJ</sub> = 1.3 V	1	01	0.21	1.11	V
			2		0.21	1.11	
			3		0.12	1.04	
		M,D,P,L,R	1	0.21	1.11		
Temperature adjust/power down function (T <sub>ADJ</sub> ) section.							
Input voltage	V <sub>dis</sub>	High voltage to disable	1,2,3	01	2.4		V
			M,D,P,L,R		1	2.4	
	V <sub>adj</sub>	Voltage without disable	1,2,3			1.3	
			M,D,P,L,R		1		
Input current	I <sub>ADJmin</sub>	T <sub>ADJ</sub> = 0 V	1	01	-160		μA
			2,3		-160		
			M,D,P,L,R		1	-160	
	I <sub>ADJmax</sub>	T <sub>ADJ</sub> = 2.4 V	1			290	
			2,3			290	
			M,D,P,L,R		1		
Power supply interface (V <sub>POS</sub> ) section.							
Quiescent supply current	I <sub>Q</sub>	RF in = -55 dBm	1	01	24	33	mA
			2		33	42	
			3		17	24	
			M,D,P,L,R		1	24	
Disabled supply current	I <sub>dis</sub>	T <sub>ADJ</sub> /V <sub>dis</sub> = 2.4 V	1	01	50	250	μA
			2		100	300	
			3		0	200	
			M,D,P,L,R		1	50	

See footnotes at end of table.

<b>STANDARD MICROCIRCUIT DRAWING</b> DLA LAND AND MARITIME COLUMBUS, OHIO 43218-3990	SIZE <b>A</b>		<b>5962-11203</b>
		REVISION LEVEL <b>A</b>	SHEET 18

TABLE I. Electrical performance characteristics – Continued.

Test	Symbol	Conditions <u>1/ 2/ 3/ 4/</u> -55°C ≤ T <sub>A</sub> ≤ +125°C V <sub>POS</sub> = 2.7 V unless otherwise specified	Group A subgroups	Device type	Limits		Unit
					Min	Max	
RF input pulse response time section continued.							
V <sub>O</sub> rise time: <u>7/</u> 10% to 90% RF in = no signal to 0 dB at 100 MHz	t <sub>RISE</sub>	CLPF = open, 50 μs pulse	9	01		28.9	ns
			10			29.6	
			11			28.0	
		CLPF = 1000 pF, 50 μs pulse	9			4.9	μs
			10			4.6	
			11			4.4	
V <sub>O</sub> fall time: <u>7/</u> 90% to 10% RF in = no signal to 0 dB at 100 MHz	t <sub>FALL</sub>	CLPF = open, 50 μs pulse	9	01		27.4	ns
			10			27.2	
			11			30.0	
		CLPF = 1000 pF, 50 μs pulse	9			7.5	μs
			10			8.4	
			11			6.7	

- 1/ RHA devices supplied to this drawing have been characterized at level R of irradiation. However, this device is tested only at the "R" level. Pre and Post irradiation values are identical unless otherwise specified in Table I. When performing post irradiation electrical measurements for any RHA level, T<sub>A</sub> = +25°C.
- 2/ These parts may be dose rate sensitive in a space environment and may demonstrate enhanced low dose rate effects. Radiation end point limits for the noted parameters are guaranteed only for the conditions specified in MIL-STD-883, method 1019, condition A.
- 3/ The TADJ voltage is set to minimize deviation. At ≤ 100 MHz, voltage for TADJ = 0.9 V; at 900 MHz, voltage for TADJ = 0.85 V; at 2.14 GHz, voltage for TADJ = 0.83 V; and at 4 GHz, voltage for TADJ = 0.9 V.
- 4/ Unless otherwise specified, V<sub>SET</sub> is tied to V<sub>OUT</sub> and CLPF is connected to a 1 nF capacitor. Refer to section 6.7 for application notes.
- 5/ Slope, intercept, and deviation are referred to a linear-regression best-fit line using -20 dBm to -40 dBm data.
- 6/ Input RF level set to cause V<sub>OUT</sub> to be 1.0 V when V<sub>OUT</sub> pin is unloaded. A current load is increased until V<sub>OUT</sub> changes -1% (0.99 V); this is I<sub>OMAX</sub> (55 mA normally). Then the current load is lowered (negative) until V<sub>OUT</sub> changes +1% (1.01 V); this is I<sub>OMIN</sub> (-650 μA normally).
- 7/ Parameter is guaranteed by engineering characterization, not production tested. Characterization repeated after receipt of subsequent wafer lots, major design or process changes. Parameter not tested post irradiation.
- 8/ The TADJ voltage can minimize deviation or place the device into shutdown. The device is active when the TADJ voltage is within the V<sub>dis</sub> range limit. The device is shutdown when the TADJ voltage is within the V<sub>dis</sub> range limit. Refer to section 6.7 for application notes.

<b>STANDARD MICROCIRCUIT DRAWING</b> DLA LAND AND MARITIME COLUMBUS, OHIO 43218-3990	SIZE <b>A</b>		<b>5962-11203</b>
		REVISION LEVEL <b>A</b>	SHEET 19

Device type	01	
Case outline	X	
Terminal number	Terminal symbol	Description
1	NC/GND	Not connected / ground.
2	NC/GND	Not connected / ground.
3	V <sub>POS</sub>	Positive supply voltage (V <sub>POS</sub> pins tied).
4	INHI	Radio frequency (RF) input. AC coupled RF input.
5	INLO	Radio frequency (RF) common for INHI. AC coupled RF common.
6	V <sub>POS</sub>	Positive supply voltage (V <sub>POS</sub> pins tied).
7	COMM	Device common. (COM pins tied.)
8	NC/GND	Not connected / ground.
9	COMM	Device common. (COM pins tied.)
10	NC/GND	Not connected / ground.
11	TADJ	Temperature compensation adjustment. Frequency dependent temperature compensation is set by applying a specified voltage to the pin. The TADJ pin has dual functionality as a power down pin, PWDN. Applying a voltage of V <sub>POS</sub> – 0.3 V disables the device.
12	COMM	Device common. (COM pins tied.)
13	V <sub>SET</sub>	Set point input for operation in controller mode. To operate in received signal strength indicator (RSSI) mode short V <sub>SET</sub> to V <sub>OUT</sub> .
14	V <sub>OUT</sub>	Logarithmic / error output.
15	NC/GND	Not connected / ground.
16	CLPF	Loop filter capacitor pin. In measurement mode, this capacitor pin sets the pulse response time and video bandwidth. In controller mode, the capacitance on this node sets the response time of the error amplifier / integrator.

NOTES.

1. No internal circuitry connected to NC/GND pins so user may ground pin if desired.
2. Metal package lid can be grounded.

FIGURE 1. Terminal connections.

<b>STANDARD MICROCIRCUIT DRAWING</b> DLA LAND AND MARITIME COLUMBUS, OHIO 43218-3990	SIZE <b>A</b>		<b>5962-11203</b>
		REVISION LEVEL A	SHEET 20

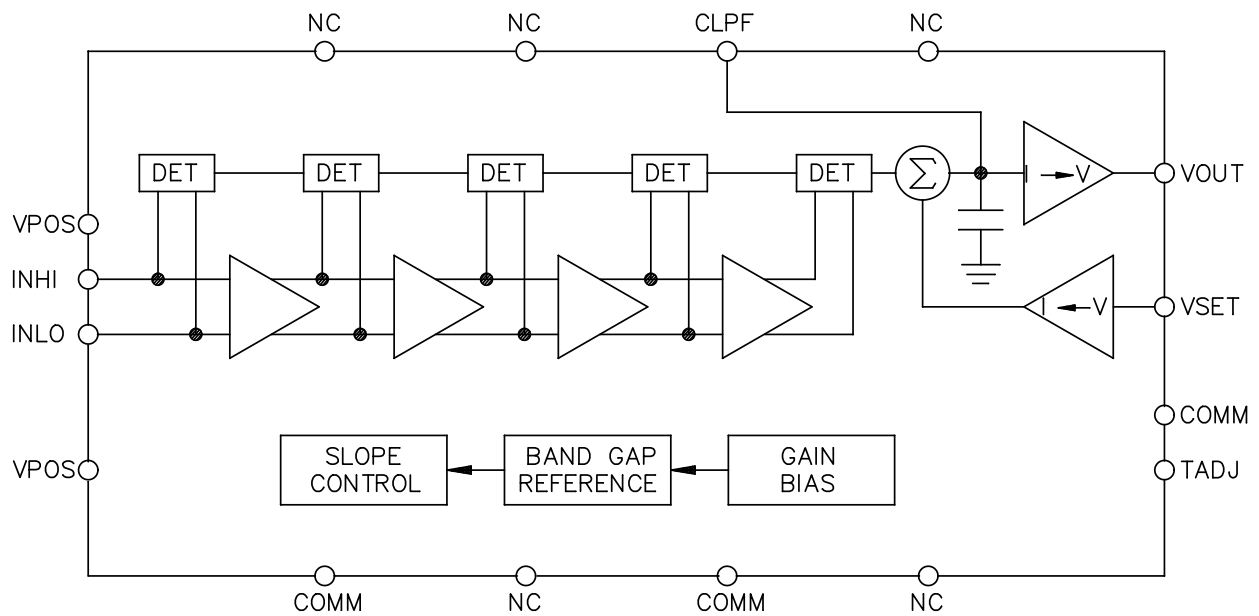

FIGURE 2. Block diagram.

**STANDARD  
MICROCIRCUIT DRAWING**  
DLA LAND AND MARITIME  
COLUMBUS, OHIO 43218-3990

SIZE  
**A**

**5962-11203**

REVISION LEVEL  
**A**

SHEET  
**21**

3.6 Certificate of compliance. For device classes Q and V, a certificate of compliance shall be required from a QML-38535 listed manufacturer in order to supply to the requirements of this drawing (see 6.6.1 herein). The certificate of compliance submitted to DLA Land and Maritime-VA prior to listing as an approved source of supply for this drawing shall affirm that the manufacturer's product meets, for device classes Q and V, the requirements of MIL-PRF-38535 and herein.

3.7 Certificate of conformance. A certificate of conformance as required for device classes Q and V in MIL-PRF-38535 shall be provided with each lot of microcircuits delivered to this drawing.

4. VERIFICATION

4.1 Sampling and inspection. For device classes Q and V, sampling and inspection procedures shall be in accordance with MIL-PRF-38535 or as modified in the device manufacturer's Quality Management (QM) plan. The modification in the QM plan shall not affect the form, fit, or function as described herein.

4.2 Screening. For device classes Q and V, screening shall be in accordance with MIL-PRF-38535, and shall be conducted on all devices prior to qualification and technology conformance inspection.

4.2.1 Additional criteria for device classes Q (class level B) and V (class level S).

- a. Burn-in test, method 1015, test condition A, B, C, or D of MIL-STD-883. The burn-in test duration, test condition and test temperature, or approved alternatives shall be as specified in the device manufacturer's QM plan in accordance with MIL-PRF-38535.
  - (1) The burn-in test circuit shall be maintained under document revision level control of the device manufacturer's Technology Review Board (TRB) in accordance with MIL-PRF-38535, and shall be made available to the acquiring or preparing activity upon request. The test circuit shall specify the inputs, outputs, biases, and power dissipation, as applicable, in accordance with the intent specified in method 1015 of MIL-STD-883.
  - (2) Dynamic burn-in is required, and shall be performed per method 1015, condition D. The test circuit shall specify the inputs  $V_{IN}$  = square wave or sine wave, clock frequency, duty cycle,  $V_{POS}$ , input resistors/output resistors connections as applicable, and shall be documented in the QM plan.
  - (3) Static burn-in is required, and shall be performed per method 1015, condition B. The test circuit shall specify the inputs connections through the resistors to  $V_{POS}$  or ground and  $V_{POS}$  as applicable, and shall be documented in the QM plan. The control signal shall be in their proper logical state to ensure DUT is under operation.
  - (4) Post electrical burn-in measurement for PDA calculation shall be read and recorded after each static burn-in and dynamic burn-in.
- b. Interim and final electrical test parameters shall be as specified in table IIA herein.
- c. Additional screening for device class V beyond the requirements of device class Q shall be as specified in MIL-PRF-38535, appendix B.

4.3 Qualification inspection for device classes Q and V. Qualification inspection for device classes Q and V shall be in accordance with MIL-PRF-38535. Inspections to be performed shall be those specified in MIL-PRF-38535 and herein for groups A, B, C, D, and E inspections (see 4.4.1 through 4.4.4).

<b>STANDARD MICROCIRCUIT DRAWING</b> DLA LAND AND MARITIME COLUMBUS, OHIO 43218-3990	SIZE <b>A</b>		<b>5962-11203</b>
		REVISION LEVEL A	SHEET 22

TABLE IIA. Electrical test requirements.

Test requirements	Subgroups (in accordance with MIL-PRF-38535, table III)	
	Device class Q	Device class V
Interim electrical parameters (see 4.2)	1	1
Final electrical parameters (see 4.2)	1,2,3,4, <u>1/ 2/</u> 5,6,9,10,11	1,2,3, <u>1/ 2/ 3/</u> 4,5,6,9,10,11
Group A test requirements (see 4.4)	1,2,3,4,5,6, <u>2/</u> 9,10,11	1,2,3,4,5,6, <u>2/</u> 9,10,11
Group C end-point electrical parameters (see 4.4)	1,2,3,4,5,6, <u>2/</u> 9,10,11	1,2,3,4,5,6, <u>2/</u> 9,10,11
Group D end-point electrical parameters (see 4.4)	1,2,3,4,5,6	1,2,3,4,5,6
Group E end-point electrical parameters (see 4.4)	1,4	1,4

1/ PDA applies to subgroup 1.

2/ See Table I for parameters tested or characterized for subgroups 1, 2, 3, 9, 10, and 11. Characterization is repeated after receipt of subsequent wafer lots, major design or process changes.

3/ Delta limits as specified in table IIB shall be required where specified, and the delta limits shall be computed with reference to the zero hour electrical parameters (see table I).

TABLE IIB. Burn-in and operating life test delta parameters.  $T_A = +25^\circ\text{C}$ . 1/ 2/

Parameters	Symbol	Condition	Delta limits		Units
Supply current	$I_Q$	$V_S = 5\text{ V}$	-1.0	1.0	mA
High voltage swing	$V_{Omax}$	$V_S = 5\text{ V}$	-0.1	0.1	V
Low voltage swing	$V_{Omin}$	$V_S = 5\text{ V}$	-0.01	0.01	V
High input current	$I_{ADJmax}$	$V_S = 5\text{ V}$	-0.01	0.01	mA
Low input current	$I_{ADJmin}$	$V_S = 5\text{ V}$	-0.01	0.01	mA
Logarithmic slope	Slope	4.0 GHz, $V_S = 2.7\text{ V}$	-0.5	0.5	mV/dB

1/ Deltas are performed at room temperature.

2/ 240 hour burn-in and 1,000 hour operating group C life test.

**STANDARD  
MICROCIRCUIT DRAWING**  
DLA LAND AND MARITIME  
COLUMBUS, OHIO 43218-3990

SIZE  
**A**

REVISION LEVEL  
A

**5962-11203**

SHEET  
23

4.4 Conformance inspection. Technology conformance inspection for classes Q and V shall be in accordance with MIL-PRF-38535 including groups A, B, C, D, and E inspections, and as specified herein.

4.4.1 Group A inspection.

- a. Tests shall be as specified in table IIA herein.
- b. Subgroups 7 and 8 in table I, method 5005 of MIL-STD-883 shall be omitted.
- c. Subgroups 1, 2, 3, 9, 10, and 11 are tested or guaranteed by engineering characterization. Characterization is repeated after receipt of subsequent wafer lots, major design or process changes.

4.4.2 Group C inspection. The group C inspection end-point electrical parameters shall be as specified in table IIA herein.

4.4.2.1 Additional criteria for device classes Q and V. The steady-state life test duration, test condition and test temperature, or approved alternatives shall be as specified in the device manufacturer's QM plan in accordance with MIL-PRF-38535. The test circuit shall be maintained under document revision level control by the device manufacturer's TRB in accordance with MIL-PRF-38535 and shall be made available to the acquiring or preparing activity upon request. The test circuit shall specify the inputs, outputs, biases, and power dissipation, as applicable, in accordance with the intent specified in method 1005 of MIL-STD-883.

4.4.3 Group D inspection. The group D inspection end-point electrical parameters shall be as specified in table IIA herein.

4.4.4 Group E inspection. Group E inspection is required only for parts intended to be marked as radiation hardness assured (see 3.5 herein).

- a. End-point electrical parameters shall be as specified in table IIA herein.
- b. For device classes Q and V, the devices or test vehicle shall be subjected to radiation hardness assured tests as specified in MIL-PRF-38535 for the RHA level being tested. All device classes must meet the postirradiation end-point electrical parameter limits as defined in table I at  $T_A = +25^{\circ}\text{C} \pm 5^{\circ}\text{C}$ , after exposure, to the subgroups specified in table IIA herein.

4.4.4.1 Total dose irradiation testing. Total dose irradiation testing shall be performed in accordance with MIL-STD-883 method 1019, condition A and as specified herein.

5. PACKAGING

5.1 Packaging requirements. The requirements for packaging shall be in accordance with MIL-PRF-38535 for device classes Q and V.

6. NOTES

6.1 Intended use. Microcircuits conforming to this drawing are intended for use for Government microcircuit applications (original equipment), design applications, and logistics purposes.

6.1.1 Replaceability. Microcircuits covered by this drawing will replace the same generic device covered by a contractor prepared specification or drawing.

6.2 Configuration control of SMD's. All proposed changes to existing SMD's will be coordinated with the users of record for the individual documents. This coordination will be accomplished using DD Form 1692, Engineering Change Proposal.

6.3 Record of users. Military and industrial users should inform DLA Land and Maritime when a system application requires configuration control and which SMD's are applicable to that system. DLA Land and Maritime will maintain a record of users and this list will be used for coordination and distribution of changes to the drawings. Users of drawings covering microelectronic devices (FSC 5962) should contact DLA Land and Maritime-VA, telephone (614) 692-8108.

<b>STANDARD MICROCIRCUIT DRAWING</b> DLA LAND AND MARITIME COLUMBUS, OHIO 43218-3990	SIZE <b>A</b>		<b>5962-11203</b>
		REVISION LEVEL A	SHEET 24

6.4 Comments. Comments on this drawing should be directed to DLA Land and Maritime-VA, Columbus, Ohio 43218-3990, or telephone (614) 692-0540.

6.5 Abbreviations, symbols, and definitions. The abbreviations, symbols, and definitions used herein are defined in MIL-PRF-38535 and MIL-HDBK-1331.

6.6 Sources of supply.

6.6.1 Sources of supply for device classes Q and V. Sources of supply for device classes Q and V are listed in MIL-HDBK-103 and QML-38535. The vendors listed in MIL-HDBK-103 and QML-38535 have submitted a certificate of compliance (see 3.6 herein) to DLA Land and Maritime-VA and have agreed to this drawing.

6.7 Application notes.

6.7.1 Power connections. The device is specified for operation up to 4 GHz; as a result, low impedance supply pins with adequate isolation between functions are essential. A power supply voltage of between 2.7 V and 5.0 V should be applied to  $V_{POS}$ . Connect 100 pF and 0.1  $\mu$ F power supply decoupling capacitors close to this power supply pin.

6.7.2 Input signal coupling. The device RF input (INHI) is single ended and must be ac coupled. Input common (INLO) should be ac-coupled to ground. Possible coupling capacitors ( $C_C$ ) are 47 nF, ceramic, 0402-style capacitors for input frequencies of 1 MHz to 4 GHz. The coupling capacitors should be mounted close to the INHI and INLO pins. The coupling capacitors values can be increased to lower the high pass cutoff frequency of the inputs stage. The high pass corner is set by the input coupling capacitor and the internal 20 pF high pass capacitor. The dc voltage on INHI and INLO is about one diode voltage drop below  $V_{POS}$ . While the input can be reactively matched, in general, this is not necessary. An external 52.3  $\Omega$  shunt resistor (connected to the signal side of the input coupling capacitors) combines with relatively high input impedance to give an adequate broadband 50  $\Omega$  match.

The coupling time constant,  $50 \times C_C/2$ , forms a high pass corner with a 3 dB attenuation at  $f_{HP} = 1/(2\pi \times 50 \times C_C)$ , where  $C_1 = C_2 = C_C$ . Using the normal value of 47 nF, this high pass corner is ~68 kHz. In high frequency applications,  $f_{HP}$  should be as large as possible to minimize the coupling of unwanted low frequency signals. In low frequency applications, a simple resistance capacitance (RC) network forming a low pass filter should be added at the input for similar reasons. This low pass filter network should generally be placed at the generator side of the coupling capacitors, thereby lowering the required capacitance value for a given high-pass corner frequency.

6.7.3 Output filtering. For applications in which maximum video bandwidth and fast rise time are desired, it is essential that the CLPF pin be left unconnected and free of any stray capacitance. The output video bandwidth, which is 10 MHz, can be reduced by connecting a ground referenced capacitor ( $C_{FLT}$ ) to the CLPF pin. This is generally done to reduce output ripple (at twice the input frequency for a symmetric input waveform such as a sinusoidal signal).

$C_{FLT}$  is selected by :  $C_{FLT} = 1 / (2\pi \times 1.5 \text{ k}\Omega \times \text{video bandwidth}) - 3.0 \text{ pF}$ .

The video bandwidth should normally be set to a frequency equal to about one tenth the minimum input frequency. This ensures that the output ripple of the demodulated log output, which is at twice the input frequency, is well filtered. In many log amplifier applications, it may be necessary to lower the corner frequency of the post demodulation filter to achieve low output ripple while maintaining a rapid response time to changes in signal level.

6.7.4 Output interface. The  $V_{OUT}$  pin is driven by a PNP output stage. An internal 10  $\Omega$  is placed in series with the output and the  $V_{OUT}$  pin. The rise time of the output is limited mainly by the slew on CLPF. The fall time is an RC-limited slew given by the load capacitance and the pull-down resistance at  $V_{OUT}$ . There is an internal pull down resistor of 1.6 k $\Omega$ . A resistive load at  $V_{OUT}$  is placed in parallel with the internal pull down resistor to provide additional discharge current. The device output can drive over 1 nF of capacitance. When driving such high output capacitive loads, it is required to capacitively load the CLPF pin. The capacitance on the CLPF pin should be at least 1/50th that of the capacitance on the  $V_{OUT}$  pin.

<b>STANDARD MICROCIRCUIT DRAWING</b> DLA LAND AND MARITIME COLUMBUS, OHIO 43218-3990	SIZE <b>A</b>		<b>5962-11203</b>
		REVISION LEVEL A	SHEET 25

6.7.5 TADJ interface. The primary component of variation in  $V_{OUT}$  versus temperature as the input signal amplitude is held constant is the drift of the intercept. This drift is also a weak function of the input signal frequency. The relationship between output voltage, frequency, and temperature is not linear and cannot easily be modeled. Experimentation is required to select the optimum  $V_{TADJ}$  voltage.

Recommended TADJ values:  $T_A = 85^\circ\text{C}$ .

100 MHz	0.89 V
900 MHz	0.86 V
1.9 GHz	0.80 V
2.14 GHz	0.84 V
2.6 GHz	0.83 V
3.6 GHz	0.90 V

The variation in  $V_{OUT}$  versus TADJ as temperature is held constant has two important points: where the linear error is zero (minimum error at a fixed temperature) and where the linear error is flattest ( $\Delta\text{error} / \Delta\text{temperature}$  is minimum, error is constant over small  $\Delta\text{temperature}$ ).

Recommended TADJ values:  $f = 1.9\text{ GHz}$ ,  $\Delta\text{error} / \Delta\text{temperature}$  is minimum.

-55°C to 0°C	0.68 V
0°C to +45°C	0.80 V
+45°C to +85°C	0.90 V
+85°C to +125°C	1.00 V

Recommended TADJ values:  $f = 1.9\text{ GHz}$ , minimum error .

-45°C	0.75 V
-20°C	0.78 V
0°C	0.85 V
+25°C	0.80 V
+45°C	0.68 V
+65°C	0.75 V
+85°C	0.80 V
+105°C	0.83 V
+125°C	0.87 V

<b>STANDARD MICROCIRCUIT DRAWING</b> DLA LAND AND MARITIME COLUMBUS, OHIO 43218-3990	SIZE <b>A</b>		<b>5962-11203</b>
		REVISION LEVEL A	SHEET 26

STANDARD MICROCIRCUIT DRAWING BULLETIN

DATE: 14-03-26

Approved sources of supply for SMD 5962-11203 are listed below for immediate acquisition information only and shall be added to MIL-HDBK-103 and QML-38535 during the next revision. MIL-HDBK-103 and QML-38535 will be revised to include the addition or deletion of sources. The vendors listed below have agreed to this drawing and a certificate of compliance has been submitted to and accepted by DLA Land and Maritime-VA. This information bulletin is superseded by the next dated revision of MIL-HDBK-103 and QML-38535. DLA Land and Maritime maintains an online database of all current sources of supply at <http://www.landandmaritime.dla.mil/Programs/Smcr/>.

Standard microcircuit drawing PIN <u>1/</u>	Vendor CAGE number	Vendor similar PIN <u>2/</u>
5962R1120301VXA	24355	ADL5513AF/QMLR

1/ The lead finish shown for each PIN representing a hermetic package is the most readily available from the manufacturer listed for that part. If the desired lead finish is not listed contact the vendor to determine its availability.

2/ Caution. Do not use this number for item acquisition. Items acquired to this number may not satisfy the performance requirements of this drawing.

Vendor CAGE  
number

24355

Vendor name  
and address

Analog Devices  
Route 1 Industrial Park  
P.O. Box 9106  
Norwood, MA 02062  
Point of contact: 7910 Triad Center Drive  
Greensboro, NC 27409-9605

The information contained herein is disseminated for convenience only and the Government assumes no liability whatsoever for any inaccuracies in the information bulletin.